

INSIDE or CEILING MOUNT and VALANCE (CONTINUED)

Step 4: Install the track underneath the valance. NOW tighten the screws to secure the track.

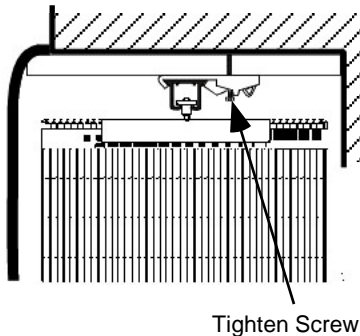

IM INSTALL IS NOW COMPLETE

INSIDE or CEILING MOUNT without valance

Follow steps 2 through 4 for Inside Mount with valance, mounting your IM bracket into the top of the window/soffit or ceiling.

IM INSTALL IS NOW COMPLETE

END STOP INSTALLATION (Optional)

Your Averté Natural Fold™ is designed to open both ways. IF one way only operation is preferred follow the steps below:

Step 1: When sliding the round carrier wheels into the track, slide an End Stop between the first and second carrier wheel.



End Stop

Step 2: Slide the first carrier and the End Stop all the way to the end of the track and then tighten the end stop in place so that the first carrier wheel does not slide.

SPLICING RAILS (Optional)

Splicers can be used with ceiling or wall mount applications and with all types of brackets. Prepare the two pieces of track, snap the splice onto one half then snap the other half into place (tip: place track face up, so you can use your body weight to snap the track in place).

Make sure that there are brackets close to the splice (2" - 4" on each side). This splice is NOT a bracket.

Note: The hole in the splice is not for ceiling mount. It was used during the powder coating process.



Splicer

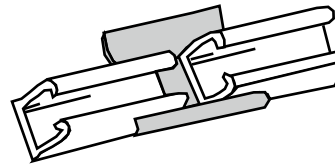

GUARANTEE

LIMITED LIFETIME GUARANTEE

Your Horizons™ Averté Natural Fold™ is protected against defects in material to the original buyer for 3 years. All colors tend to lose their original intensity over time. This is considered normal wear and tear, and is not covered by this Guarantee. Abuse, misuse and improper installation are not covered. Finally, color lots vary and may not exactly match the sample in your sample book or a previously ordered shade. Repair is the purchaser's sole remedy under this guarantee. B&W cannot be responsible for any installation costs nor costs of incidental or consequential damages.

INSTALLATION INSTRUCTIONS FOR

Horizons™ Averté Natural Fold™

By B&W Manufacturing



Congratulations on the purchase of your new
Horizons™ Averté Natural Fold™!

OUTSIDE MOUNT

Step 1: Firmly attach the OM brackets to the wall. The two end brackets should be within 3" of the end of the track. Space any additional brackets evenly. Care should be taken to ensure all brackets are level.

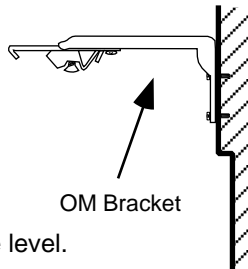

Step 2: Attach an end cap on one end of the track. Install the track into the brackets and tighten the screw.

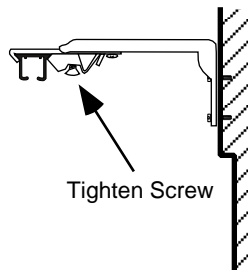

Step 3: From the open end of the track, slide the round carrier wheels into the track. Once all the carriers are in the track, attach the track's end cap.

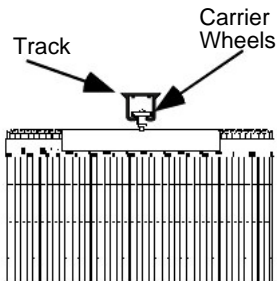

If you ordered a valance with your Averté Natural Fold™, continue, otherwise the install is complete.

OUTSIDE MOUNT WITH VALANCE

Step 4: Set the valance board on top of the now hanging brackets, all the way back, flush with the wall.

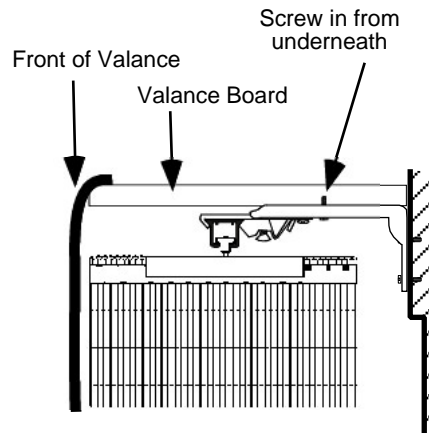

Step 5: Use a 5/8" self tapping screw at each bracket, up from underneath into the headboard of the valance.

Step 6: The valance returns attach to the ends of the valance board with velcro.

OM INSTALL IS NOW COMPLETE

INSIDE or CEILING MOUNT and VALANCE

Step 1: If you ordered a valance with your folding door, it is installed first. Install the valance inside the window opening, and screw up through the board into the top of the window/soffit or ceiling. It is okay if the front of the valance projects out from the opening.

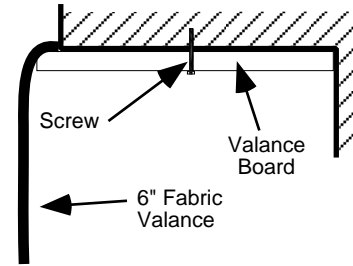

Step 2: Attach the IM brackets to the underside of the valance board. It should be positioned so that the rail will be in the center of the board. DO NOT tighten the screw all the way.

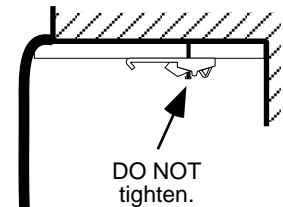

Step 3: From the open end of the track, slide the round carrier wheels into the track. Once all the carriers are in the track, attach the track's end cap.

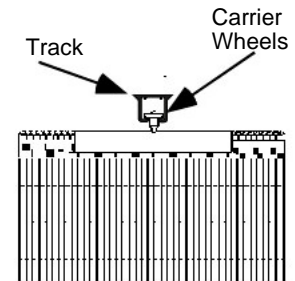

CONTINUE...